



# Exhaust Systems Engine Mounts Carb Air Boxes

Shrouds • Seats • Piston • Turbine • Radial • Vintage • And More...



## CESSNA 206H STATIONAIR

WITH LYCOMING IO-540-AC1A5 ENGINE

SN 20608000 AND ON

Item	Part Number	Description
1	9954300-9	MUFFLER ASSY RH & LH
2	9954300-8	SHROUD RIGHT HAND
3	9954300-7	SHROUD LEFT HAND
4	9954300-6	STACK ASSY RIGHT HAND
5	9954300-5	STACK ASSY LEFT HAND
6	9954300-12	TAILPIPE RIGHT HAND (9954300-4)
7	9954300-11	TAILPIPE LEFT HAND (9954300-3)
8	1254007-1	CLAMP HALF TAILPIPE
9	0750161-22	CLAMP HALF TAILPIPE
-	628260	GASKET
-	1250360-15	INDUCTION AIR BOX
-	011-250	SPRING KIT
-	0514213-1	SEAT BASE FRAME

 Inspect collector just before the ball joint for heat distortion and black flaking material.

- This muffler does not require flame cones.
- Inspect tailpipe for thinning and internal corrosion.
- Some of the parts for this aircraft are Inconel. Although Inconel is a far superior metal, it is more difficult to inspect. Inconel tends to corrode from the inside without showing signs of flaking or bulging like stainless steel. The carbon on the inside of the exhaust parts should be removed to properly inspect the components. If the welds are developing pinholes the component may not pass an internal inspection.

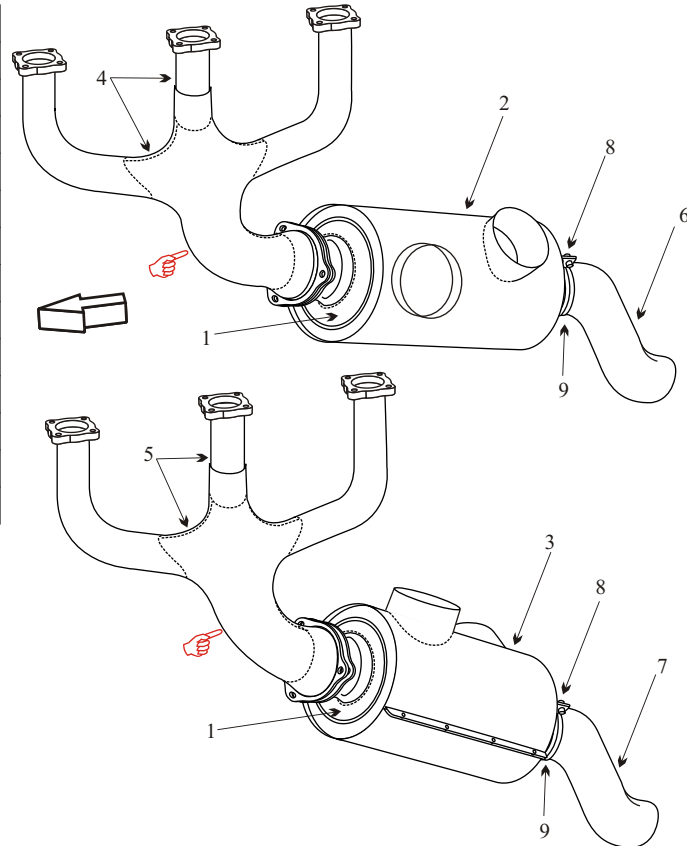

(toll free) 1-888-388-8803 1-780-447-5955 Fax: 1-780-447-5980  
sales@acornwelding.com parts@acornwelding.com www.acornwelding.com