

**PIPER PA-28R-180 (PIPER ARROW)**  
**PIPER PA-28R-200 (PIPER ARROW II)**  
**PIPER PA-28R-201 (PIPER ARROW III)**  
**PIPER PA-28RT-201 (PIPER ARROW IV)**

Item	Part Number	Description	Code
1	67517-000	MUFFLER	
2	67651-000	SHROUD TOP	A
3	99600-000	SHROUD TOP	
4	67808-000	SHROUD BOTTOM	
5	67809-000	STACK RIGHT FRONT	
5	67619-000	STACK RIGHT FRONT	B
6	67810-000	STACK LEFT FRONT	
6	67617-000	STACK LEFT FRONT	B
7	67811-000	STACK LEFT REAR	
7	67618-000	STACK LEFT REAR	B
8	67812-000	STACK RIGHT REAR	
8	67620-000	STACK RIGHT REAR	B
9	63243-002	CLAMP	
-	67779-000	ALTERNATE AIR HOUSING	
-	67119-049	ENGINE MOUNT(SL 568)	C
-	67119-057	ENGINE MOUNT	D
-	67119-058	ENGINE MOUNT	E
10	67119-061	ENGINE MOUNT	F
-	77611	GASKET	
-	SEAT BASE		

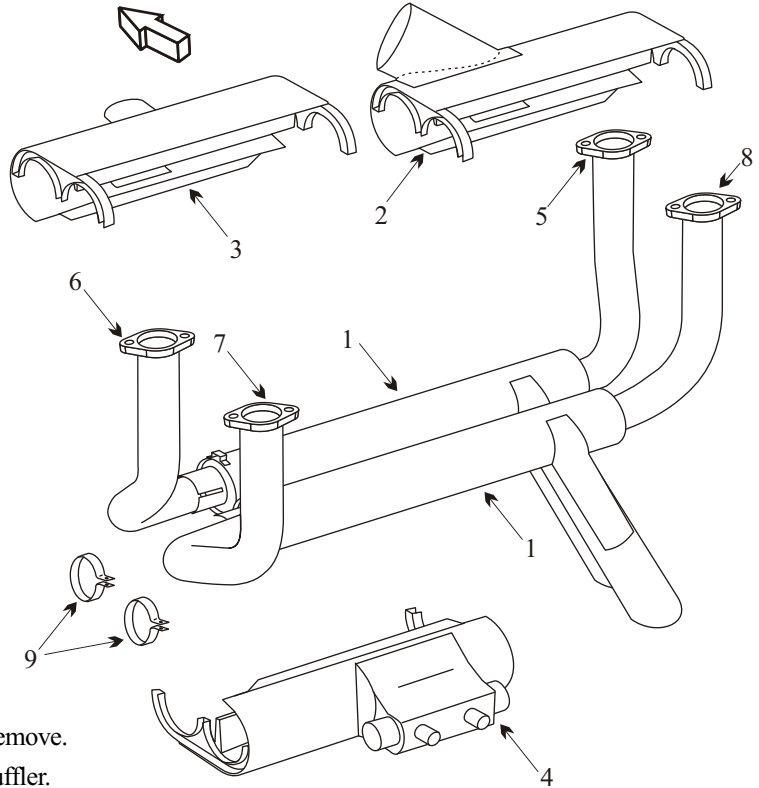

- The riser stacks flare into the muffler making them difficult to remove.
- Inspect muffler for wear areas where the shroud rests on the muffler.

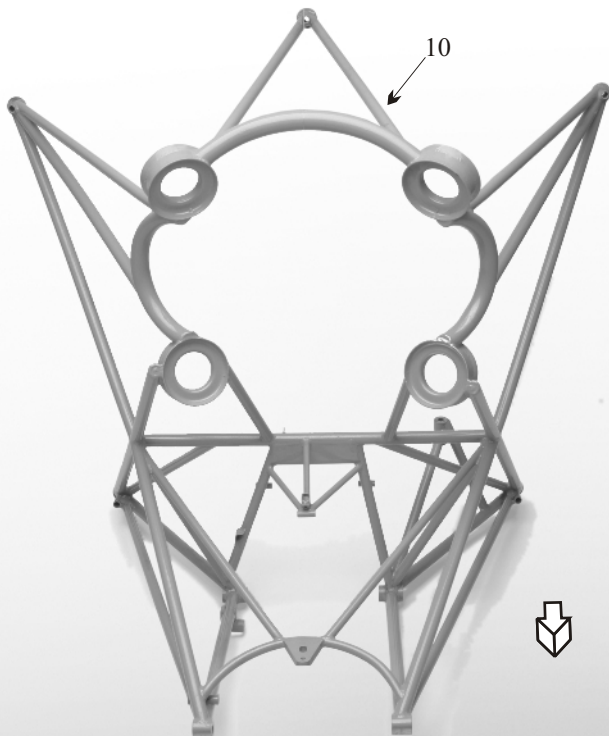

### Usable On Codes

- A : SN 28R-30005 – 28R-31279  
 SN 28R-35001 – 28R-7135238
- B : PA-28R-180 Only
- C : SN 28R-30005 – 28R-7130019 (PA-28R-180)  
 SN 28R-35001 -28R7335455 (PA28R-200)
- D : SN 28R7435001 and UP (PA28R-200)  
 SN 7435001-8018098 (PA28RT-201)  
 SN 28R-7737002 - 28-7837317 (PA28R-201)  
 SN 2837001 – 2837061 (PA28R-201)
- E : SN 2844001 and UP (PA-28R-201)
- F : SN 8018099 And on (PA28RT-201)

#### AD 80-19-01

Applies to S/N's 28R-30002 thru 28R-7130013.  
 Ensure there is a minimum gap of .030" between  
 shroud end plates.