

PIPER PA-28-140/150/160/180 SN 28-0001-1760 CHEROKEE SN 28-20002-26956 SN 28-7125001-7725290

Item	Part Number	Description	Code
1	99482-000	MUFFLER 140/150/160	
1	99482-002	MUFFLER 180	
2	63652-002	SHROUD SN 28-1 28-1520	
3	62208-002	SHROUD SN 28-1521 to 28-1760 28-20002 to 28-24999	
4	66704-002	SHROUD SN 28-25000 and on	
5	63726-004	STACK RIGHT FRONT SN 28-0001 to 28-1760 28-20002 to 28-7125471	
6	99044-004	STACK RIGHT REAR SN 28-0001 to 28-1760 28-20002 to 28-7125471	
7	63726-002	STACK LEFT FRONT SN 28-0001 to 28-1760 28-20002 to 28-7125471	
8	99044-003	STACK LEFT REAR SN 28-0001 to 28-1760 28-20002 to 28-7125471	
9	99044-002	STACK RIGHT FRONT SN 28-7125472 and on	G
10	99044-005	STACK LEFT FRONT SN 28-7152472 and on	G
11	63666-002	TAILPIPE	
12	63723-003	CARB HEAT SHROUD TOP	
13	63723-002	CARB HEAT SHROUD BOTTOM	
14	14235-000	CLAMP TAILPIPE 2"	
15	65442-003	CLAMP STACK WITH PIN	
-	SEE PAGE "2"	AVCON MUFFLER O360 CONVERSION	
-	77611	GASKET	
-	63601-013	CARB AIR BOX	E
-	63680-000	CARB AIR BOX	F
-	63300-008	HORN NOSEWHEEL STEERING	
-	63964-000	SUPPORT ENGINE CONTROL SN 28-1761 4377	
-	69317-000	SUPPORT ENGINE CONTROL	G
-	63600-024	ENGINE MOUNT SN 1 220	A
-	63600-028	ENGINE MOUNT SN 221 507	
-	63694-000	ENGINE MOUNT	B
-	66662-000	ENGINE MOUNT SN 25000 and on	D
-	66662-014	ENGINE MOUNT	D
-	VARIOUS	SEAT BASE	
-	J-7402-16	SHOCK MOUNT	H
-	J-9613-40	SHOCK MOUNT	I
-	J-7402-24	SHOCK MOUNT	C, J

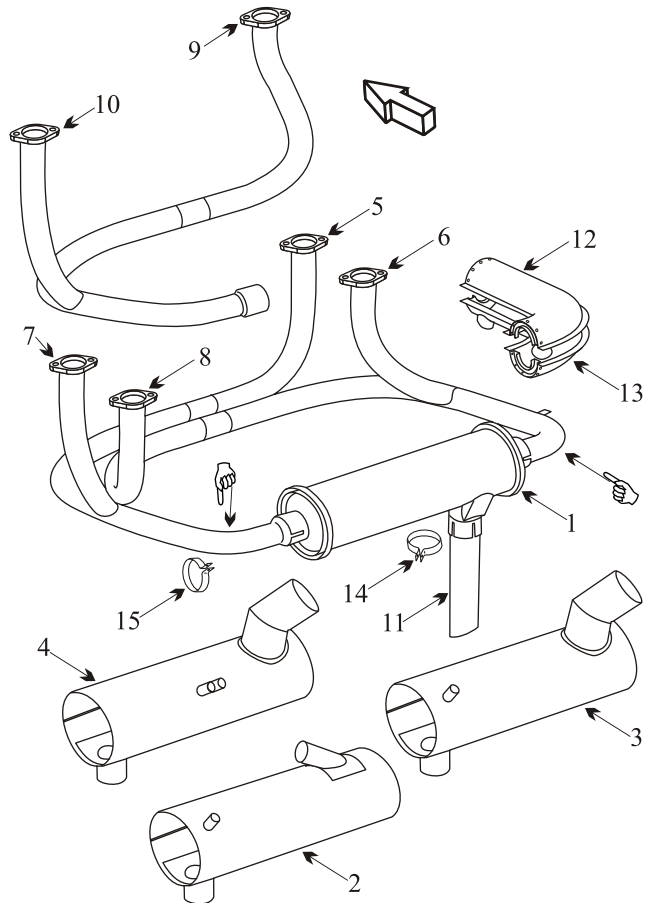

Usable on Codes

- A: PA-28-140 SN 28-1 to 220, if kit #754-428 order PN 63600-028
- B: PA-28-150, 160, 180 SN 28-508 to 1760
PA-28-140 SN 28-20002 to 24999
- C: PA-28-150, 160, 180 SN 28-1761 to 5149
- D: PA-28-140 SN 28-25000 and on,
PA-28-180 SN 28-5150 and on
- E: PA-28-150 & 160 SN 28-1 to 1760
PA-28-140 SN 28-20002 and on
- F: PA-28-180 only SN 28-671 to 1760
- G: PA-28-140 only
- H: PA-28-140 SN 20002 to 24999,
PA-28-150 SN 1 to 1478,
PA-28-160 SN 28-508 to 28-1478
- I: PA-28-140 SN 25000 to 25641
- J: PA-28-150 SN 1479 to 1760
PA-28-330 to 4377

• Inspect the Y-joint at the aft cylinder stack for cracks.

☞ This part has a hot area at the elbow. Inspect this area for black flaking metal and bulges.

AD 70-16-05

PA-28-140

Applies to S/N's 28-20001 thru 28-26400 with muffler P/N 63627-000 or 63688-000.

PA-28-150/160/180

Applies to S/N's 28-03, 28-1 thru 28-1760A with muffler P/N 63627-000 or 63688-000.

Inspect muffler for cracks, burn-through, weld separations and failed internal baffles.

Less than 950 hrs of operation inspect every 100 hrs.

More than 950 hrs of operation inspect every 50 hrs.

Recurring inspections may be discontinued when muffler P/N 99482-000 installed.

AD 62-26-06

PA-28-150/160

Applies to 23-03, 28-1 thru 28-671, 28-678, 28-679, 28-681, 28-685, 28-690, 28-691, 28-693, 28-697, 28-706 and 28-707 except with exhaust assembly P/N 63726 installed.

Inspect complete exhaust system for cracks at joints and tube bends.

Inspection required every 50 hrs of operation.